



OFFICE OF THE ATTORNEY GENERAL
STATE OF ILLINOIS

Lisa Madigan
ATTORNEY GENERAL

August 9, 2017

**VIA CERTIFIED MAIL
RETURN RECEIPT REQUESTED**

Brickyard Fields Dog Park
City Hall
207 S. East Street
Le Roy, IL 61752

RE: Brickyard Fields Dog Park, Le Roy, IL
2018-DRC-6081

Dear Sir/Madam:

The Brickyard Fields Dog Park is currently under investigation by the Disability Rights Bureau of Illinois Attorney General Lisa Madigan's office. The Disability Rights Bureau is responsible for enforcement of state and federal laws which protect people with disabilities in the State of Illinois. We received a complaint alleging that the Brickyard Fields Dog Park located in, Le Roy, IL is in violation of Title II of the Americans with Disabilities Act, 42 U.S.C. §§ 12131 – 12165, Section 504 of the Rehabilitation Act of 1973, 29 U.S.C. § 794, the Environmental Barriers Act, 410 ILCS 25/1 to 25/8 and the Illinois Human Rights Act, 775 ILCS 5. Specifically, the complaint alleges that the Brickyard Fields Dog Park fails to provide an accessible pathway that is in compliance with state and federal law for people with disabilities. In order to assist our investigation, we request the following information within 30 days of receipt of this letter:

1. The names and contact information of any city employees responsible for coordinating ADA compliance and investigating complaints of ADA noncompliance.
2. The original date of construction for the Brickyard Fields Dog Park and its parking lot.
3. Information about any alterations that have been made to the Brickyard Fields Dog Park since its initial construction, including but not limited to any resurfacing, painting or other improvements to the Brickyard Fields Dog Park. For each alteration, please provide:
 - a. The date the alterations began and were completed.

- b. A description of the alterations.
4. If you have been investigated by any other government agency for violations of disability laws, please provide the following for each investigation:
 - a. The date of the investigation.
 - b. A description of the nature of the alleged violations.
 - c. The name and address of the government agency.
 - d. A description of the way in which the matter was resolved.
 - e. Copies of any written agreements, consent decrees, court orders, or other documents used to resolve the investigation.
5. If you have received any complaints, formal or informal, relating to accessibility to services or discrimination on the basis of disability, please provide the following for each complaint:
 - a. The name, address and telephone number of the individual who complained.
 - b. A description of the complaint.
 - c. The date of the complaint and the date on which the incident complained of took place.
 - d. The way the complaint was resolved.
 - e. Copies of any documents used to resolve the complaint.

Please submit your responses to our Springfield office, *in writing*, within 30 days receipt of this letter. If you have any questions please contact me at (217) 785-0087 or by e-mail at JeJones@atg.state.il.us.

Sincerely, 

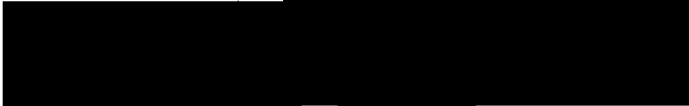
Jennée Jones, Accessibility Specialist
Disability Rights Bureau
Office of the Attorney General
500 S. Second Street
Springfield, IL 62706

August 29, 2018

Jénnee Jones
Accessibility Specialist
Disability Rights Bureau
Office of Attorney General
500 South Second Street
Springfield, IL 627706

**DISABILITY
RECEIVED**

SEP 04 2018

**Attorney General
SPRINGFIELD**

Re: Brick Yard Fields Dog Park
2018 DRC 6081

Dear Ms. Jones:

Please be advised that we represent the City of LeRoy in connection with the above-described matter. This letter is in response to your letter dated August 9, 2017. In your letter you ask for the following information:

- (1) Names and contact information of any City employees responsible for coordinating ADA compliance and investigating complaints of ADA non-compliance.

Answer: City Administrator David Jenkins, 207 South East Street, LeRoy, IL 61852, telephone (309) 962-3031. Email: djenkins@leroy.org.

- (2) The original date of construction for the Brick Yard Fields dog park and its parking lot.

Answer: Spring/summer 2017.

- (3) Information about any alterations that have been made to the Brick Yard Fields dog park since its initial construction.

Answer: None.

- (4) If you have been investigated by any other government agency for violations of disability laws, please provide the following for each investigation.

Answer: Not applicable.

ANCEL, GLINK, DIAMOND, BUSH, DiCIANNI & KRAFTHEFER, P.C.

August 29, 2018

Page 2

- (5) If you have received any complaints, formal or informal, relating to accessibility to services or discrimination on the basis of disability, please provide the following for each complaint.

Answer: Not applicable.

We look forward to working with you and the complainant in order to resolve this matter. Please feel free to contact me by email at smahrt@ancelglink.com, or telephone (309) 828-1996, address 202 North Prospect, #203, Bloomington, Illinois 61704.

Very truly yours,

A solid black rectangular redaction box covering the signature area.

Steven D. Mahrt

4841-0247-0769, v. 1



OFFICE OF THE ATTORNEY GENERAL

STATE OF ILLINOIS

October 4, 2019

KWAME RAOUL
ATTORNEY GENERAL

Steven D. Mahrt
Ancel Glink
202 N. Prospect Road, Suite 203
Bloomington, IL 61704
smahrt@ancelglink.com

Re: *Brickyard Field Dog Park, LeRoy, IL*
2018-DRC-6081

Dear Mr. Mahrt:

As you know, the Disability Rights Bureau of Illinois Attorney General Kwame Raoul's office received a complaint alleging that Brickyard Field Dog Park does not comply with Title II of the Americans with Disabilities Act ("ADA"), 42 U.S.C. §§ 12131 – 12134, and the regulations implementing Title II, the 2010 ADA Standards for Accessible Design ("Standards"), 28 C.F.R. Pt. 35; the Environmental Barriers Act ("EBA"), 410 ILCS 25/1 to 25/8 and its implementing code, the Illinois Accessibility Code ("IAC"), 71 Ill. Admin. Code, Pt. 400.

The IAC, which took effect on May 1, 1988, requires every state or local government facility constructed or altered on or after May 1, 1988, to comply with its minimum accessibility requirements. The ADA which took effect on January 26, 1992, requires that every state or local government facility constructed or altered on or after that date meet the minimum accessibility requirements contained in the Standards.

On October 29, 2018, our office conducted a site inspection of the Brickyard Field Dog Park. Because the construction of Brickyard Field Dog Park began in 2017, we inspected the park for compliance with the new construction requirements of the EBA and ADA. During our inspection, we found elements of the park that are not in compliance with these laws. This letter and its accompanying attachment set forth our factual findings and the relevant statutory and regulatory requirements under the EBA, IAC, ADA, and the Standards.

Pursuant to Section 6 of the EBA, 410 ILCS § 25/6, and Section 400.140 of the IAC, 71 Ill. Admin. Code 400.140, the Attorney General has the authority to commence an action to seek civil penalties in an amount not to exceed \$250 per day that a facility is in violation of the EBA. However, we would like to work to resolve this matter and avoid litigation. To do that, we would

Brickyard Field Dog Park, Leroy, IL
2018-DRC-6081

be willing to enter into a voluntary agreement with the city of LeRoy by which you agree to bring the violations found in Attachment A into compliance with the EBA and ADA.

We request that within thirty (30) days of receipt of this letter, you submit a written proposal for bringing the elements found in Attachment A into compliance with the EBA, IAC, ADA, and the Standards. In your proposal, please include drawings of any construction or modifications to be done and an estimated timeline for completing each part of the project. After reviewing the proposal, we will contact you to discuss it further. **Please do not make any modifications to the park without our approval.** We will require that all modifications necessary to bring the violations found in Attachment A into compliance with the EBA and ADA be made within 3 months of our approval of your proposal.

We look forward to hearing from you. If you have any questions, please contact me at (217) 785-0087 or by e-mail at JeJones@atg.state.il.us.

Sincerely,



Jennée Jones, Disability Specialist
Disability Rights Bureau
Office of the Illinois Attorney General
500 S. Second Street
Springfield, IL 62706

Enclosures:

Encl. 1 - Violations Attachment A

Encl. 2 - OAG Accessible Parking for People with Disabilities brochure (DRAFT)

**Brickyard Field Dog Park
207 S. East Street
LeRoy, IL 61752
2018-DRC-6081**

Attachment A¹

I. Parking

1. Where parking spaces are provided, parking spaces shall be provided in accordance with 208 [no accessible parking spaces provided]. IAC § 400.310(c)(1); Standards §§ 208.1.

II. Accessible Routes

Route Leading to the Park

2. At least one accessible route shall be provided within the site from the accessible parking spaces and accessible passenger loading zones; public streets and sidewalks; and public transportation stops to the accessible building or facility entrance they serve [no accessible route to entrance of dog park due to gravel parking lot and grassy field]. IAC § 400.310(a)(1)(A); Standards § 206.2.1.

Route Within the Park

3. At least one accessible route shall connect accessible buildings, accessible facilities, accessible elements, and accessible spaces that are on the same site [no accessible route provided within the dog park]. Standards § 206.2.2

III. Entrances

4. Entrances shall be provided in accordance with 206.4. Entrance doors, doorways, and gates shall comply with 404 and shall be on an accessible route complying with 402 [slope of asphalt near gates exceeds 5%, grass is located in the required maneuvering clearance for gates]. IAC §§ 400.310(j)(2), 400.310(k)(1); Standards § 206.4.

IV. Toilet Rooms

5. Where toilet rooms are provided, each toilet room shall comply with 603 [the portable toilet unit is not accessible]. Standards § 213.2.

¹ All measurements provided in brackets reflect the data collected at Brickyard Field Dog Park by the Attorney General's Office during a site visit conducted on October 29, 2018.

V. **Benches**

6. Benches shall comply with 903 [bench is located in grass]. IAC § 400.310(w)(2); Standards § 903.1.

A Message from
ILLINOIS ATTORNEY GENERAL
KWAME RAOUL



As Attorney General, it is my job to ensure that all Illinois residents, including people with disabilities, receive equal protection under the law. I am committed to working on behalf of people with disabilities to provide them with complete accessibility.

My office's Disability Rights Bureau employs a full-time staff that strives to make schools, the workplace and all public facilities open and available to everyone.

Questions and complaints about accessible parking represent one of the largest categories of inquiries to the Bureau. I hope that this brochure provides you with a clear understanding of the accessible parking laws.

If you have a question, see an improperly marked accessible parking space or find a facility without any accessible parking spaces, please contact the Disability Rights Bureau.

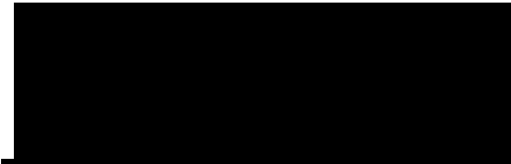

Kwame Raoul
Attorney General



If you see an improperly marked accessible parking space, or facilities with no such spaces, you can contact the Disability Rights Bureau with your complaint. Complaints can also be filed online at <http://www.illinoisattorneygeneral.gov/rights/disabilityrights.html>.

DISABILITY RIGHTS BUREAU

CHICAGO

100 West Randolph Street
Chicago, Illinois 60601
1-312-814-5684
TTY: 1-800-964-3013

SPRINGFIELD

500 South Second Street
Springfield, Illinois 62701
1-217-524-2660
TTY: 1-877-844-5461

For more information about Illinois parking laws visit <https://www2.illinois.gov/cdb/announcements/2018/Documents/Register%20Page.pdf>.

www.IllinoisAttorneyGeneral.gov

Printed by authority of the State of Illinois. 06/19
This material is available in alternate format upon request.

ACCESSIBLE PARKING

FOR PEOPLE WITH DISABILITIES

A GUIDE TO YOUR RIGHTS UNDER THE LAW



KWAME RAOUL
ILLINOIS ATTORNEY GENERAL

Accessible Parking: Know the Rules

Any facility offering parking for employees or visitors must provide accessible parking for people with disabilities. An accessible parking space consists of a vehicle space and a diagonally striped access aisle. The entire space must be kept clear of obstructions—including ice, snow, shopping cart corrals, trash cans, seasonal garden displays and bicycle racks—at all times.

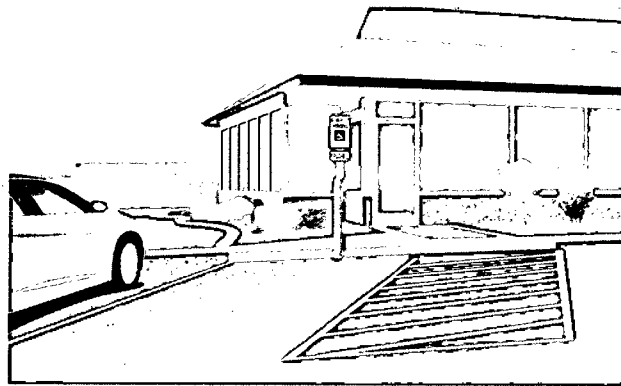

Illustration of a legal angled accessible parking space.

SIZE AND MARKINGS

Each accessible parking space, except on-street spaces, shall be 16 feet wide, including either an eight-foot or five-foot wide diagonally striped access aisle. The access aisle may be located on either side of the vehicle space except for angled parking spaces, which shall have the access aisle located on the passenger side of the vehicle space. Access aisles shall be marked with diagonal striping so as to discourage parking in them. Two parking spaces may share an access aisle except for angled parking spaces. High-quality yellow paint, manufactured especially for pavement striping, must be used.

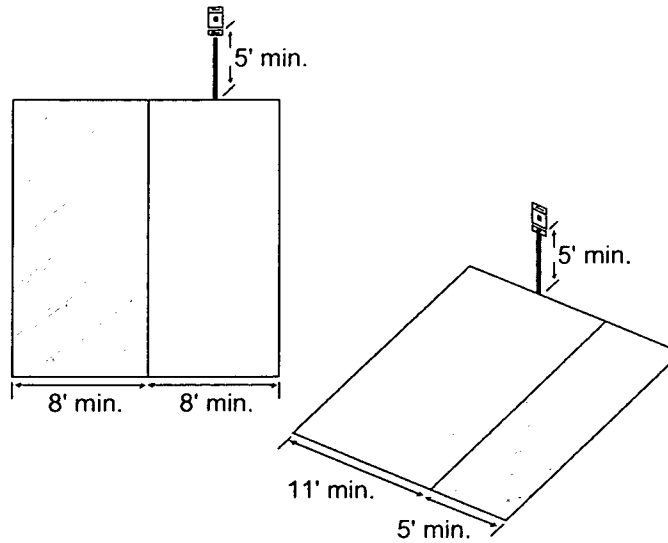

Illustration of two examples of legal accessible parking spaces.

LOCATION

Accessible parking must be placed on level pavement on the shortest accessible route to an accessible facility entrance. The accessible route, which may include a curb ramp or curb cut, must be installed as close as possible to the accessible entrance it serves. Additionally, a curb ramp must never be built so that it protrudes into or interferes with the diagonally striped access aisle of an accessible space.

SIGNS

A U.S. Department of Transportation R7-8 (Reserved Parking) and R7-I101 (\$250 Fine) sign must be permanently mounted in the center of the parking space. The signs must be vertically mounted on a post or wall at front center of the parking space, no more than 6 feet horizontally from the front of the parking space. At a minimum, the bottom of the R7-8 sign must be 5 feet from the pavement. Municipalities may impose a larger fine through the adoption of a local ordinance.

PROPER USE OF LICENSE PLATES/PLACARDS
Under Illinois law, disability license plates, disabled veterans plates and placards are not transferable. The authorized holder must be present and must enter or exit the vehicle at the time the parking privileges are being used. Unauthorized use can result in a \$600 fine, driver's license suspension and suspension or revocation of the plate or placard by the Illinois Secretary of State.

SPACE REQUIREMENTS

To comply with Illinois law, a minimum number of accessible parking spaces must be provided:

Total Off-Street Parking Spaces Provided	Number of Accessible Parking Spaces Required
1 to 25	1
26 to 50	2
51 to 75	3
76 to 100	4
101 to 150	5
151 to 200	6
201 to 300	7
301 to 400	8
401 to 500	9
501 to 1,000	2% of total
over 1,000	20 plus 1 for each 100 over 1,000

Outpatient facilities providing medical care and other services for persons with mobility impairments 10% of total

Medical facilities specializing in treatment of persons with mobility impairments 20% of total



A Professional Corporation
202 N. Prospect Road, Suite 203
Bloomington, IL 61704
www.ancelglink.com

Steven D. Mahrt
smahrt@ancelglink.com
(P) 309.828.1996
(F) 309.828.1994

October 7, 2019

DISABILITY
RECEIVED

OCT 16 2019

Attorney General
SPRINGFIELD

Jènnée Jones
Disability Specialist
Disability Rights Bureau
Office of the Illinois Attorney General
500 South Second Street
Springfield, IL 62706

**Re: Brickyard Field Dog Park, LeRoy, Illinois
Case No. 2018-DRC-6081**

Dear Ms. Jones:

Thank you for your letter of October 4, 2019. I have forwarded your letter to the City of LeRoy. Please be advised that the City intends to respond to your request for a remediation plan within the next thirty days.

While awaiting the City's proposed remediation plan, is it possible for you to review the enclosed information provided to me by the City? It is my understanding that the cost of providing an accessible path of travel to the dog park will approach 90% of the cost of constructing the dog park. When the other improvements suggested in your letter of October 4, 2019 are added to the remediation plan the cost of remediation will exceed the cost of constructing the dog park.

In reviewing the Illinois Accessibility Code, I see that Section 202.4 appears to provide some relief where the cost of providing an accessible path of travel exceeds 20% of the cost of the primary function area. Am I reading this section of the accessibility code correctly in concluding that the accessible path of travel is not required due to the disproportionate cost of constructing such pathway?

In order to appropriately respond to your request for a remediation plan, it will also be helpful if you indicate whether or not the City could simply remove the dog park facility. I am not suggesting that the City intends to remove the dog park facility, but in providing my advice to the City, it would be helpful to know your position regarding this option. I see in your letter of October 4, 2019 you indicated the City is not to make any modifications to the park without your approval.

Another section of the Code may factor into the response by the City. Section 203.12 – Animal Containment Areas, states that the animal cages, pens, corrals and similar areas in which animals are contained shall be on an accessible route, but shall not otherwise be required to comply with

ANCEL GLINK

October 7, 2019
Page 2

the Accessibility Code. Does this section apply to the dog park or affect any of the deficiencies identified in the attachment to your October 4, 2019 letter?

I am also wondering what your position or response is in the event the portable restroom facility and picnic table are removed from the site.

We look forward to working with you to resolve this matter in a mutually satisfactory manner. Your advice and assistance is appreciated and I look forward to hearing from you regarding the questions and advice requested herein.

Sincerely,

A large black rectangular redaction box covers the signature area.

Steven D. Mann

Enclosure

4832-8575-3513, v. 1

**BRICKYARD FIELDS DOG PARK
ADA COST ESTIMATE**

August 9, 2018

<u>ITEM</u>	<u>DIMENSIONS</u>	<u>QUANTITY</u>	<u>UNIT COST</u>	<u>COST</u>
SIDEWALK	300' x 5' x 5"	25 CY	\$115.00 CY	\$2,875.00
ENTRY PAD	22' x 6' x 5"	3 CY	\$115.00 CY	\$345.00
½' REBAR		680 LF	\$0.80	\$544.00
CA-6 SUBBASE	300' x 4' x 2"	15 TONS	\$22.00 \$	\$330.00
18" CULVERT	25'	1	\$16.50 P FT	\$412.50
SINGLE-AXLE TRUCK		16 HRS	\$36.00 HR	\$576.00
BACKHOE		16 HRS	\$62.00 HR	\$992.00
BOBCAT SKIDSTEER W/TILT BLADE		20 HRS	\$60.50 HR	\$1,210.00
<u>MANHOURS</u>		175 HRS	\$52.35 HR	\$9,161.25

TOTAL COST FOR ADA IMPROVEMENTS: \$16,445.75

TOTAL ORIGINAL COST OF DOG PARK: \$18,900.00

COST DIFFERENTIAL = \$2454.25

217-258-8181 Mattoon
 217-351-3051 Champaign
 309-828-6464 Bloomington
 217-258-8182 Fax

BROOKS CREEK CEDAR

brookscreek@consolidated.net
 www.brookscreekcedar.com
 2120 Marshall Ave., Mattoon, IL 61938

proposal submitted to: City of Le Roy c/o David Jenkins, City Admin.		home 1-309-962-3031	estimate Updated 5-11-2017
street address:		work Djenkins@LeRoy.org	target install date: (subject to change)
		cell 1-309-242-5339 Josh	
city Le Roy	zip code: 61752	email: Jmullis@leroy.org	GPS: N: W:
county:	township:	cross-street:	Subd: referred

Layout:

CITY OF LE ROY DOG PARK

CUSTOM CHAIN LINK FENCE

937' of 6' tall Galv. Chain Link

- Commercial Grade 9-gauge
- Tension Wire @ Bottom
- 7-8 Holes Cut Thru Concrete Pad
- 4 - 4' wide Gates
- 2 - 12' Double Gates
- SS-20 Heavy Duty Top-Rail
- 3" Heavy Duty Gate Posts

FENCE TO FOLLOW CONTOUR OF GROUND

unless specified on proposal

Customer to:

- Obtain permit, if required, from city, county or homeowners association.
- Mark or paint any areas unmarked by JULIE, including but not limited to: sprinkler, sump pump lines, drain tiles and private electric/ gas lines
- Provide plat of survey or have all property lines clearly marked
- Brooks Creek Cedar will not be held liable for placement of fence

Dirt to be: left on plastic hauled for fee

TOTAL COST: \$ 18,900.00

DEPOSIT AMOUNT: \$ _____ (ck/ap#) _____

BALANCE AMOUNT: \$ _____ (ck/ap#) _____

(balance due upon completion, payable to installation crew)

****TARGET install date is subject to change (due to weather and/or construction delays)**
****BROOKS CREEK will call J.U.L.I.E. but will not be held liable for damage to lines or obstructions UNMARKED by J.U.L.I.E.**

All material is guaranteed to be as specified. All work to be done in a workmanlike manner according to standard practices. Any alterations or deviations from the above specifications involving extra cost will be executed only upon written orders, and will become an extra charge over and above the proposal. All agreements contingent upon strikes, accidents, or delays beyond our control. Owner to carry fire, tornado and other necessary insurance. Our workers are fully covered by Workman's Compensation insurance.

Authorized signature Chad Clark

Note: Proposal may be withdrawn by us if not accepted within _____ days.

Date of acceptance _____ Customer's Signature _____

BUYER'S RIGHT TO CANCEL: YOU, THE BUYER, MAY CANCEL THIS TRANSACTION AT ANY TIME PRIOR TO MIDNIGHT OF THE THIRD BUSINESS DAY AFTER THE DAY OF THIS TRANSACTION.